

## Motorspannschienen aus Stahl

### Steel slide bases

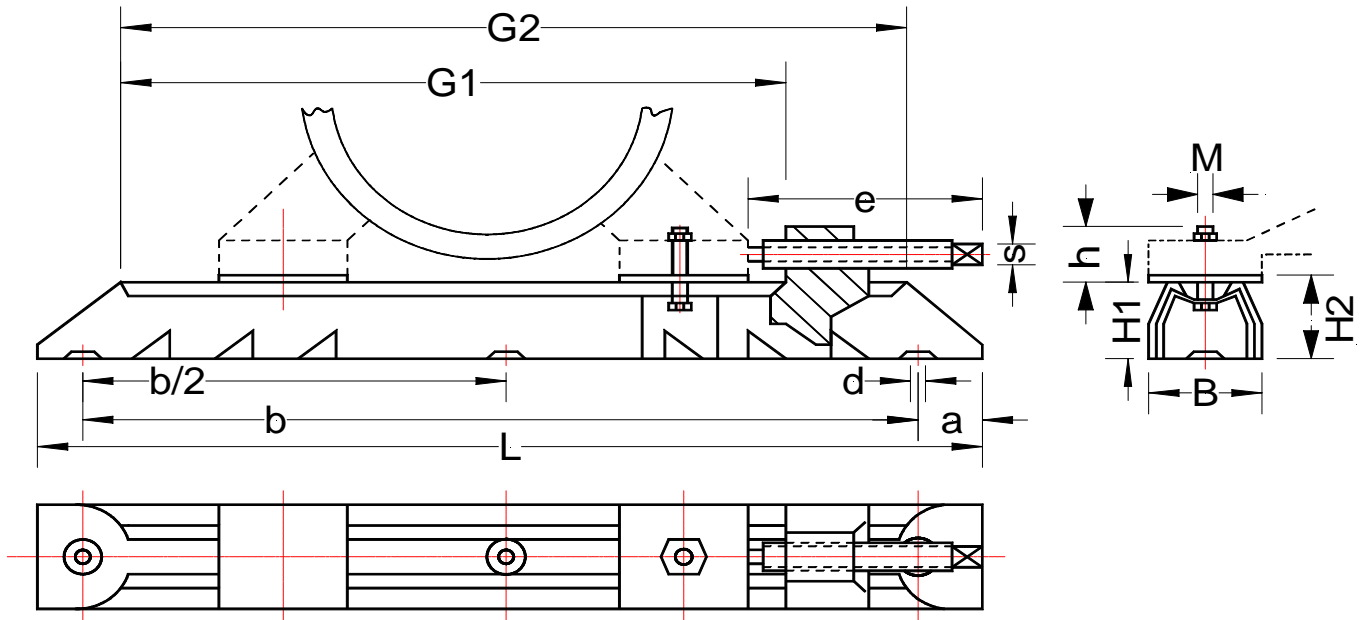

Type	Gesamtlänge total length L	Gleitlänge slide length G1	Motor-Baugröße motor-type											Gewicht weight kg	
				M x h	e x s	G2	a	b	b/2	Ø d	B	H1	H2		
<b>mit versetzbaren Spannklöben</b>				<b>with movable blocks</b>											
312/6	312	240	63/71	M 6x19	75x 6	262	16	280	-	12	40	28	30	1,4	
312/8	312	240	80/90	M 8x27	75x 6	262	16	280	-	12	40	28	30	1,5	
375/6	375	305	63/71	M 6x19	75x 6	325	16	343	-	12	40	28	30	1,5	
375/8	375	305	80/90	M 8x27	75x 6	325	16	343	-	12	40	28	30	1,6	
375/10	375	305	100/112	M 10x32	75x 6	325	16	343	-	12	40	28	30	1,6	
395/8	395	302	80/90	M 8x28	97x 8	325	20	355	-	12	50	40	43	3,4	
395/10	395	302	100/112	M 10x35	97x 8	325	20	355	-	12	50	40	43	3,4	
495/8	495	405	80/90	M 8x29	97x 8	425	20	455	-	12	50	40	43	4,0	
495/10	495	405	100/112/132	M 10x35	97x 8	425	20	455	-	12	50	40	43	4,0	
495/12	495	405	160	M 12x49	97x 8	425	20	455	-	12	50	40	43	4,0	
530/10	530	413	132	M 10x37	119x 9	442	25	480	-	14	60	50	54	6,4	
530/12	530	413	160	M 12x49	119x 9	442	25	480	-	14	60	50	54	6,4	
630/10	630	515	132	M 10x37	119x 9	542	25	580	-	14	60	50	54	8,2	
630/12	630	515	160/180	M 12x45	119x 9	542	25	580	-	14	60	50	54	8,2	
686/12	686	538	160/180	M 12x43	154x 12	575	28	630	315	18	75	60	64	12,8	
686/16	686	538	200/225	M 16x62	154x 12	575	28	630	315	18	75	60	64	12,8	
<b>mit angeschweißten Spannklöben</b>				<b>with welded blocks</b>											
864/16	864	700	200/225	M 16x60	300x 16	810	32	800	400	24	90	75	-	16,6	
864/20	864	700	250/280	M 20x68	300x 16	810	32	800	400	24	90	75	-	16,6	
1072/20	1072	865	250/280	M 20x77	360x 19	995	36	1000	500	30	112	100	-	33,4	
1072/24	1072	865	315	M 24x88	360x 19	995	36	1000	500	30	112	100	-	33,5	
1330/24	1330	1065	315/355	M 24x95	430x 21	1215	40	1250	625	30	130	125	-	56,6	