

Material: GG 22-25
 Design: All pulleys as solid type or plate type
 with or without holes.

Borderform for flat belt pulleys according to DIN 111 / ISO 100

Bulging height h [mm]

d [mm]	Width of border b [mm]							n max ca. [1/min]
	32	50	80	100	125	160	200	
63	0,3							12.130
67	0,3							11.400
71	0,3							10.760
75	0,3							10.190
80	0,3	0,3	0,3					9.550
85	0,3	0,3						8.990
90	0,3	0,3	0,3	0,3				8.490
95	0,3	0,3						8.040
100	0,3	0,3	0,3	0,3				7.640
106	0,3	0,3						7.210
112	0,3	0,3						6.820
118	0,3	0,3						6.470
125	0,3	0,3	0,4	0,4	0,4			6.110
132	0,3	0,3	0,4					5.790
140	0,3	0,3	0,4	0,4	0,4			5.460
150	0,3	0,3	0,4	0,4	0,4	0,4		5.090
160	0,3	0,3	0,4	0,4	0,5	0,5		4.770
170		0,3	0,4					4.490
180	0,3	0,3	0,4	0,4	0,5	0,5		4.240
190	0,3	0,3	0,4					4.020
200	0,3	0,3	0,5	0,5	0,6	0,6		3.820
212	0,3	0,3	0,5	0,5				3.600
224	0,3	0,3	0,5	0,5	0,6	0,6		3.410
236	0,3		0,5	0,5	0,8			3.240
250	0,3	0,3	0,5	0,5	0,8	0,8		3.060
265	0,3				0,8			2.885
280	0,3	0,3	0,5	0,5	0,8	0,8	0,8	2.730
300		0,3	0,5	0,5				2.550
315	0,3	0,3	0,5	0,5	0,8	0,8	0,8	2.430
335			0,5		0,8			2.280
355	0,3	0,3	0,5	0,5	0,8	0,8	0,8	2.150
400	0,3	0,3	0,6	0,6	1,0	1,0	1,0	1.910
450	0,3	0,3	0,6	0,6	1,0	1,0	1,0	1.700
500	0,3	0,3	0,6	0,6	1,0	1,0	1,0	1.530
560		0,3	0,6	0,6	1,2	1,2	1,2	1.360
630	0,3	0,3	0,6	0,6	1,2	1,2	1,2	1.210

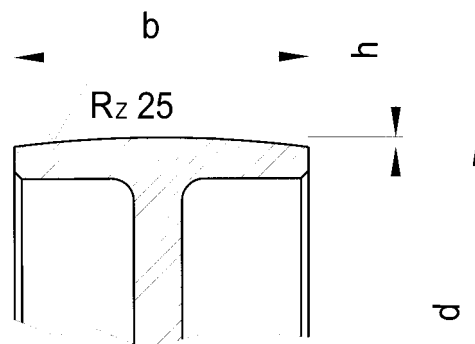

Material	Solid / plate pulley	
	Solid pulley	Arm pulley
Aluminium	50	45
GG 20	40	35
GG 25	42	38
GG 40	60	54
GGG 40	60	54
GGG 50	60	54
GGG 70	80	70
Steel	>80	>70

Pulleys with bulging height indication are available ex -stock. Please inquire regarding other dimensions and versions.

Admissible peripheral velocities in m/s for various materials. Material of the flat belt pulleys kept in stock: GG 20.25

Balancing quality grade G 6,3 for n = 1450 1/min or 30 m/s as from d = 355 mm

Technical information for flat belt pulleys

Some comments on flat belt drives

Nowadays flat belt drives are again being more widely used since they have a series of advantages compared with V-belt drives:

- Higher degree of efficiency, up to 99% (single groove V-belts approx. 97%, multi groove approx. 92%)
- The life span is up to 4 times greater than with V-belt drive.
- The noise emission is 10-20 db lower than with V-belt drive.
- Almost wear and tear free free operation and thus bw maintenance requirement, subsequent tensioning is not normally necessary.

However, when using flat belt drives attention must be paid to the fact that for troublefree operation a stable construction must be present which enables permanent correct alignment of the flat belt pulley.

The acquisition costs for flat belt drives are higher than for V-belt drives.

Assembly instructions

Each flat belt drive must be dimensioned in accordance with the drive data, whereby the calculated bearing expansion must be observed during assembly.

A defined length is marked on the belt which, following tensioning, must be longer by the pretensioning. (e.g. 1000mm + 2% = 1020mm in a tensioned state)

Exact alignment of the flat belt pulleys is necessary, too great an alignment error manifests itself in a drifting off of the belt. Before the trial run, rotate the disks in both directions by hand in order to check the running of the belt.

During initial assembly: First of all pretension with 70% of the calculated bearing expansion, put into operation for 30-60 minutes and then increase to the final pretension.

Normally, subsequent tensioning is not necessary following reaching of the required pretension.

Use of flat belt pulleys with collar

Particularly in the ventilation industry, flat belt pulleys with collar are being used to an increasing extent in order to prevent the drifting off of the belts during the start up phase.

Permanent contact of the belt with the collar leads to the destruction of the belt, therefore it is also imperative that attention must be paid to correct alignment of the pulleys.

b = 32

d	Buchse bush	Nabe hub		Bild illustr.	Typ type	S	T	U	Gewicht weight kg
		Länge length	Lage position						
63	1108	23	bü	2	●	0	23	9	0,40
67	1108	23	bü	2	●	0	23	9	0,45
71	1210	26	bü	2	●	0	26	6	0,52
75	1210	26	bü	2	●	0	26	6	0,61
80	1210	26	bü	2	●	0	26	6	0,70
85	1210	26	bü	2	●	0	26	6	0,78
90	1610	26	bü	2	●	0	26	6	0,80
95	1610	26	bü	2	●	0	26	6	0,96
100	1610	26	bü	2	●	0	26	6	1,04
106	1610	26	bü	2	●	0	26	6	1,18
112	1610	32	bü	2	●	0	26	6	1,30
118	1610	26	bü	2	●	0	26	6	1,60
125	1610	26	bü	2	●	0	26	6	1,66
132	2012	32	bü	2	●	0	26	6	2,06
140	2012	32	bü	2	●	0	32	0	1,90
150	2012	32	bü	2	○	10	12	10	3,00
160	2012	32	bü	2	○	8	14	10	3,50
180	2012	32	bü	2	○	12	8	12	3,80
190	2517	45	bü	2	○	12	8	12	4,15
200	2517	45	bü	1	○	12	8	12	4,32
212	2517	45	bü	1	○	12	8	12	4,70
224	2517	45	bü	1	○	12	8	12	4,90
236	2517	45	bü	1	○	12	8	12	5,40
250	2517	45	bü	1	○	12	8	12	5,60
265	2517	45	bü	1	○	9	14	9	5,90
280	2517	45	bü	1	○	13	9	10	6,20
315	2517	45	bü	1	○	11	12	8	7,60
355	2517	45	bü	1	○	10	12	10	11,10
400	2517	45	bü	1	○	8	16	8	14,60
450	2517	45	bü	1	○	9	14	9	16,20
500	3020	52	bü	1	○	10	10	12	14,00
630	3020	52	bü	1	○	10	10	12	17,00

b = 50

d	Buchse bush	Nabe hub		Bild illustr.	Typ type	S	T	U	Gewicht weight kg
		Länge length	Lage position						
63	1108	23	bü	2	●	0	23	27	0,45
80	1210	26	bü	2	●	0	26	24	0,90
85	1210	26	bü	2	●	0	26	24	1,20
90	1610	26	bü	2	●	0	26	24	1,60
95	1610	26	bü	2	●	0	26	24	1,60
100	1610	26	bü	2	●	0	26	24	1,60
106	1610	26	bü	2	●	0	26	24	1,80
112	2012	32	bü	2	●	0	32	18	1,82
118	2012	32	bü	2	●	0	32	18	1,88
125	2012	32	bü	2	●	0	32	18	2,60
132	2012	32	bü	2	●	0	32	18	2,80
140	2012	32	bü	2	●	0	32	18	3,20
150	2012	32	bü	2	●	0	32	18	3,60
160	2012	32	bü	2	○	10	25	15	4,12
170	2517	45	bü	2	○	10	25	15	4,60
180	2517	45	bü	2	○	10	25	15	5,00
190	2517	45	bü	2	○	10	25	15	5,50
200	2517	45	bü	2	○	20	10	20	6,30
212	2517	45	bü	2	○	20	10	20	5,50
212	2517	45	bü	2	○	20	10	20	6,50
224	2517	45	bü	2	○	20	10	20	7,00
236	2517	45	bü	2	○	20	10	20	7,25
250	2517	45	bü	2	○	20	10	20	7,50
280	2517	45	bü	2	○	20	10	20	8,50
300	3020	52	bü	1	○	19	12	19	10,00
315	3020	52	bü	1	○	18	14	18	11,20
355	3020	52	bü	1	○	19	14	17	12,80
400	3020	52	bü	1	○	19	14	17	17,20
450	3020	52	bü	1	○	17	18	15	16,00
500	3535	89	bü	5	○	17	18	15	17,20
560	3535	89	bü	5	○	17	18	15	18,10
630	3535	89	bü	5	○	17	18	15	19,20

b = 80

d	Buchse bush	Nabe hub		Bild illustr.	Typ type				Gewicht weight kg
		Länge length	Lage position			S	T	U	
80	1615	38	bü	2	●	0	38	21	1,50
90	1615	38	bü	2	●	0	38	42	1,90
100	1615	38	bü	2	●	0	38	42	2,40
125	2517	45	bü	2	●	0	45	35	3,40
132	2517	45	bü	2	●	0	45	35	3,90
140	2517	45	bü	2	●	0	45	35	4,16
150	2517	45	bü	2	●	0	45	35	5,00
160	2517	45	bü	2	●	0	45	35	5,90
170	2517	45	bü	2	●	0	45	35	7,10
180	2517	45	bü	2	●	30	10	40	8,50
190	2517	45	bü	2	○	30	10	40	9,50
200	2517	45	bü	2	○	30	10	40	6,00
212	3020	52	bü	2	○	30	15	35	11,80
224	3020	52	bü	2	○	30	15	35	10,80
236	3020	52	bü	2	○	30	15	35	11,80
250	3020	52	bü	2	○	34	12	34	12,80
280	3020	52	bü	2	○	34	12	34	13,80
300	3020	52	bü	2	○	34	12	34	18,00
315	3020	52	bü	2	○	34	12	34	19,60
355	3030	77	bü	2	○	34	12	34	17,40
400	3535	89	bü	1	○	33	14	33	24,30
450	3535	89	bü	1	○	33	14	33	28,40
500	4040	102	bü	1	○	33	14	33	43,00
560	4040	102	bü	1	○	33	14	33	46,40
630	4545	114	v17	1	○	33	14	33	62,00

b = 100

d	Buchse bush	Nabe hub		Bild illustr.	Typ type				Gewicht weight kg
		Länge length	Lage position			S	T	U	
90	1615	38	rü 31	4	●	40	38	22	2,20
100	1615	38	rü 31	4	●	31	39	30	2,70
125	2517	45	rü 27	4	●	27	45	28	3,80
140	3020	52	bü	2	●	0	52	48	4,90
150	3020	52	bü	2	●	0	52	48	6,20
160	3020	52	bü	2	●	0	52	48	7,50
180	3020	52	bü	2	●	0	52	48	8,00
200	3020	52	bü	2	●	22	30	48	10,40
212	3020	52	bü	2	○	15	30	55	11,00
224	3020	52	bü	2	○	15	30	55	12,70
236	3020	52	bü	2	○	15	30	55	16,00
250	3020	52	bü	2	○	15	30	55	13,10
280	3020	52	bü	2	○	31	14	55	14,60
300	3020	52	bü	2	○	31	14	55	15,40
315	3020	52	bü	2	○	42	16	42	17,00
335	3020	52	bü	2	○	42	16	42	18,00
355	3535	52	bü	2	○	42	16	42	19,30
400	3535	89	bü	2	○	41	18	41	26,80
450	3535	89	bü	2	○	41	18	41	30,20
500	4040	102	bü	1	○	41	18	41	46,00
560	4040	102	bü	1	○	42	19	39	50,00
630	4545	114	bü	1	○	40	20	40	61,60

b = 125

d	Buchse bush	Nabe hub		Bild illustr.	Typ type				Gewicht weight kg
		Länge length	Lage position			S	T	U	
125	2517	45	rü 40	4	●	40	45	40	4,50
140	3030	77	bü	2	●	0	77	48	5,20
150	3030	77	bü	2	●	0	77	48	6,70
160	3030	77	bü	2	●	0	77	48	8,50
180	3030	77	bü	2	●	20	55	50	12,00
200	3030	77	bü	2	○	30	40	55	15,50
224	3030	77	bü	2	○	34	35	56	14,20
236	3030	77	bü	2	○	34	35	56	22,20
250	3030	77	bü	2	○	34	35	56	17,50
265	3030	77	bü	2	○	34	35	56	32,60
280	3030	77	bü	2	○	55	14	56	17,50
300	3030	77	bü	2	○	55	14	56	18,20
315	3030	77	bü	2	○	55	14	56	19,00
335	3535	89	bü	2	○	54	16	55	21,40
355	3535	77	bü	2	○	54	16	55	22,00
400	3535	89	bü	2	○	54	16	55	29,00
450	3535	89	bü	2	○	54	16	55	33,00
500	4040	102	rü 12	4	○	54	16	55	45,00
560	4040	102	rü 12	4	○	54	16	55	54,00
630	4545	114	rü 5,5	4	○	54	16	55	72,00

b = 160

d	Buchse bush	Nabe hub		Bild illustr.	Typ type				Gewicht weight kg
		Länge length	Lage position			S	T	U	
150	3030	77	bü	2	●	0	77	83	7,60
160	3030	77	bü	2	●	0	77	83	10,00
180	3030	77	bü	2	●	0	77	83	14,00
200	3030	77	bü	2	○	0	77	83	18,00
224	3030	77	bü	2	○	30	47	83	17,00
250	3030	77	bü	2	○	54	16	90	17,50
280	3535	89	bü	2	○	64	16	80	21,80
315	3535	89	bü	2	○	64	16	80	26,00
335	3535	89	bü	2	○	62	18	80	28,00
355	3535	89	bü	2	○	62	18	80	27,00
400	3535	89	bü	2	○	62	18	80	32,00
450	3535	89	bü	2	○	62	18	80	42,50
500	4040	102	rü 29	4	○	62	18	80	53,00
560	4040	102	rü 29	4	○	62	18	80	66,50
630	4545	114	rü 23	4	○	62	18	80	80,00

b = 200

d	Buchse bush	Nabe hub		Bild illustr.	Typ type				Gewicht weight kg
		Länge length	Lage position			S	T	U	
280	4040	102	bü	2	○	90	20	90	29,00
315	4040	102	bü	2	○	90	20	90	33,00
355	4040	102	bü	2	○	90	20	90	36,00
400	4040	102	bü	2	○	90	20	90	41,00
450	4040	102	rü 50	4	○	90	20	90	55,00
500	4545	114	rü 43	4	○	90	20	90	69,00
560	4545	114	rü 43	4	○	90	25	85	87,00
630	5050	127	rü 36	4	○	90	25	85	105,00